

TRASH RECEPTACLE HOLDERS

32 GAL. TRASH RECEPTACLE HOLDER MODEL # 12428

- The top ring is constructed from 7 Ga. x 2" steel for strength and durability, rolled to a 24 1/2" ID. The bottom ring is constructed from 7 Ga. x 2 1/2" steel for strength and durability, rolled to a 22 1/2" ID and reinforced with 7 Ga. x 2" steel bar straps.
- All frames are continuously welded for strength.
- Frames are available in non-toxic Gray Powder Coat or Hot-Dip Galvanized after fabrication.
- Assembly fasteners are 5/16" dia. galvanized steel carriage bolts with galvanized washers and nuts.
- Slats are available as pressure treated lumber or recycled plastic lumber and are pre-drilled for ease of installation.
- All exposed corners are chamfered for safety.
- Approximate weights:
 Frames (1 SET) = 24 lbs
 Hardware kit = 5 lbs
 P. T. Lumber (18 req.) = 60 lbs
 Recycled Plastic = 90 lbs

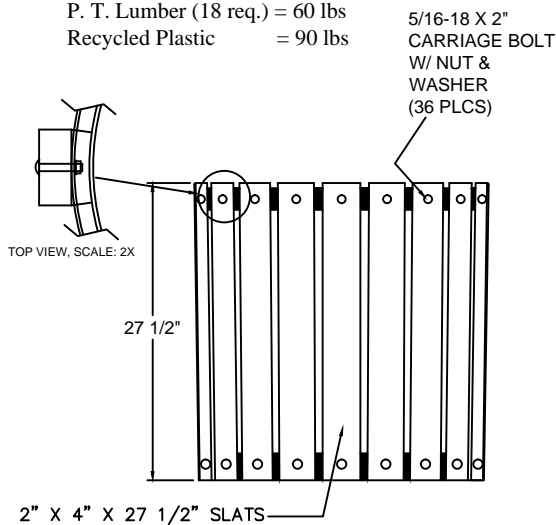

PART NUMBER	RECEPTACLE HOLDER DESCRIPTION
12428	32 GAL. TRASH RECEPT. HOLDER
PART NUMBER SUFFIX	
-1	(POWDER COATED FRAME, #1 TREATED PINE SLATS)
-2	(POWDER COATED FRAME, RECYCLED PLASTIC SLATS)
-3	(HOT-DIP GALVANIZED FRAME, #1 TREATED PINE SLATS)
-4	(HOT-DIP GALVANIZED FRAME, RECYCLED PLASTIC SLATS)
-5	(GRAY POWDER COATED FRAME ONLY)
-6	(HOT-DIP GALVANIZED FRAME ONLY)

SEE PG. 2 FOR MOUNTING OPTIONS

55 GAL. TRASH RECEPTACLE HOLDER MODEL # 12429

- The top ring is constructed from 7 Ga. x 2" steel for strength and durability, rolled to a 26" ID. The bottom ring is constructed from 7 Ga. x 3" steel for strength and durability, rolled to a 26" ID and reinforced with 7 Ga. x 2" steel bar straps.
- All frames are continuously welded for strength.
- Frames are available in non-toxic Gray Powder Coat or Hot-Dip Galvanized after fabrication.
- Assembly fasteners are 5/16" dia. galvanized steel carriage bolts with galvanized washers and nuts.
- Slats are available as pressure treated lumber or recycled plastic lumber and are pre-drilled for ease of installation.
- All exposed corners are chamfered for safety.
- Approximate weights:
 Frames (1 SET) = 29 lbs
 Hardware kit = 5 lbs
 P. T. Lumber (18 req.) = 75 lbs
 Recycled Plastic = 117 lbs

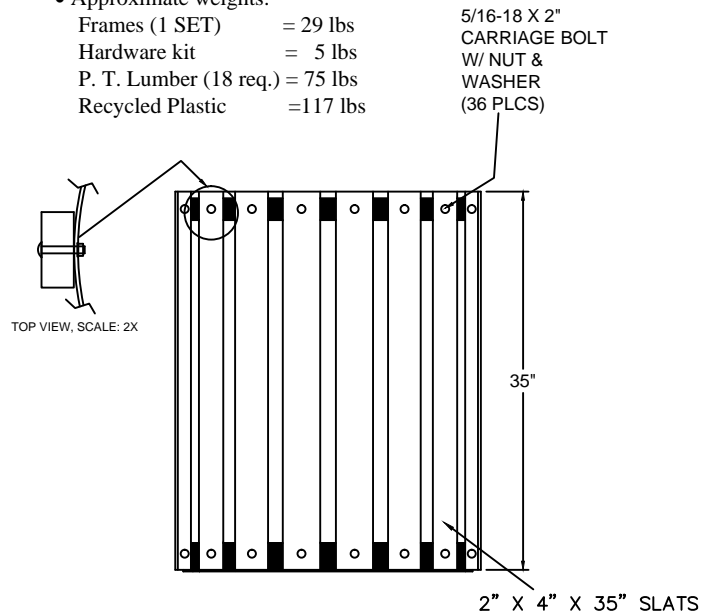

PART NUMBER	RECEPTACLE HOLDER DESCRIPTION
12429	55 GAL. TRASH RECEPT. HOLDER
PART NUMBER SUFFIX	
-1	(POWDER COATED FRAME, #1 TREATED PINE SLATS)
-2	(POWDER COATED FRAME, RECYCLED PLASTIC SLATS)
-3	(HOT-DIP GALVANIZED FRAME, #1 TREATED PINE SLATS)
-4	(HOT-DIP GALVANIZED FRAME, RECYCLED PLASTIC SLATS)
-5	(GRAY POWDER COATED FRAME ONLY)
-6	(HOT-DIP GALVANIZED FRAME ONLY)

SEE PG. 2 FOR MOUNTING OPTIONS

WARNING: MUST BE PERMANENTLY MOUNTED

CUSTOMER APPROVAL :

DATE :



THIS DRAWING, WHICH CONTAINS PROPRIETARY INFORMATION, IS THE PROPERTY OF JAMESTOWN ADVANCED PRODUCTS CORPORATION. IT SHALL NOT BE REPRODUCED IN ANY MANNER NOR DISCLOSED TO THIRD PARTIES WITHOUT WRITTEN PERMISSION OF JAMESTOWN ADVANCED PRODUCTS CORPORATION.

DATE : 11-01-04

PRODUCT PART NUMBER : 12428 (-1 THRU -6)
12429 (-1 THRU -6)

REV. NO. 2 12/11/15

PRODUCT DESCRIPTION :
TRASH RECEPTACLE, HOLDER OPTIONS

2855 GIRTS ROAD
JAMESTOWN, NY 14701